

# Bosch Ultimate Protection Plan



If any Bosch Alternator or Starter fails within two years of its installation, your car owner customer can get a Free jump start or tow, if necessary, from a qualified Road Service Provider!

The Bosch Ultimate Protection Plan lets your customers know that these top-quality parts are backed by this exclusive program. And, inside the box, your customer will find his Personal Registration Card, which, when filled out and mailed in, provides him with jump start and/or tow service for two years. No other auto parts manufacturer provides this exclusive product support program!



**24** Hour/Month  
Roadside Assistance

The Best Parts... The Best Backup... Always, and... Only from Bosch!

**PLUG IDENTIFICATION**

	BOSCH	CHRYSLER	DELCO	DUCELLIER (PARIS RHONE)	FORD	HITACHI
<b>Positive (+)</b>	B+, Bat			B+	Bat, B+	
<b>Negative (-)</b>	D-			D-		
<b>Sense (+)</b>			2, S	+	A	S
<b>Ignition (+)</b>	R		I, IG			R, IG
<b>Stator</b>	W		P, R	+	Stat, S	N
<b>Indicator</b>	D+, L		1	L		L
<b>Field</b>	DF	F(1), F(2), F	F	D+, D-	FLD, F	F
<b>Computer</b>			F			
<b>Lamp</b>			L		I	
<b>Not Used</b>			D			D

	LUCAS	MANDO	MARELLI	MITSUBISHI	MOTOROLLA	NIPPONDENSO	SEV MARCHAL
<b>Positive (+)</b>	B+			A	BAT		B+
<b>Negative (-)</b>	B-			E	D-	E	D-
<b>Sense (+)</b>	S	S		S, A		S	
<b>Ignition (+)</b>		R		R, IG, D		IG, R	
<b>Stator</b>		P		N, P		N, P	
<b>Indicator</b>	D+	L	30, D+	L	D+	L	61, D+
<b>Field</b>			67	F	DF	F	DF
<b>Computer</b>				C, G, Fr		C, FR	
<b>Lamp</b>				I			
<b>Not Used</b>				D		D	

## Troubleshooting Guide

### CHARGING SYSTEMS

#### *Before Start Static Tests*

1. The battery must be fully charged. Terminal voltage OCV for maintenance free batteries must be 12.6 volts at 100% charge. A minimum of 12.4 volts at 75% charge is necessary to properly test the system. Terminal voltage OCV of new batteries must register a minimum of 12.5 volts before installation. Recharge and retest, per manufacturer's specifications, any battery that does not meet the requirement above.
2. Check conditions of battery connections. All battery cable connections must be clean, free of corrosion, and tight. If cable ends are corroded, **do not replace just the cable ends, replace the entire battery cable.**
3. Check condition of ground strap from battery to engine, frame and body. All connections must be clean and tight.
4. If alternator is mounted in rubber grommets, check condition of ground strap from alternator; all connections must be clean and right.
5. Check tightness and condition of alternator drive belt. Belt tension and condition should be to manufacturer's specifications.

#### *System Running Test (vehicle with warm engine):*

1. Start engine and run at **2000 rpm**.
2. Create an electrical load by turning on headlights, heater blower motor, A/C, rear defroster, etc.



Fig. 4

3. Check output of alternator by measuring regulated voltage from the alternator battery terminal (B+) to ground.

4. Turn off all electrical loads. Output should remain within vehicle specifications. Refer to the vehicle manufacturer's regulated voltage specifications for the vehicle being tested.

5. Load alternator to within 10% of rate output current, using a load tester across the battery and an ammeter at the alternator terminal (B+). Voltage should remain above 12 volts, while output is within 10% of rated current.

### FAULT DIAGNOSIS

#### *Key on, engine stopped, charge indicator lamp does not light:*

Remove the wire from the alternator or regulator indicator lamp terminal and connect the wire to ground. Now, turn the ignition key to the "on" position. If the warning lamp lights, then the lamp circuit is good and the alternator is defective (internal regulator type) or the regulator is defective (external regulator type).

If the warning lamp does not light, then the lamp circuit is defective and must be repaired. Check for a defective bulb or open circuit.

---

---

## Alternator Installation Procedures

**IMPORTANT:** Before installation of replacement alternator, follow diagnostic guide on next page to ensure necessity for alternator replacement.

---

### Alternator Removal

---

1. Disconnect negative battery cable.  
**NOTE: Failure to do so may result in electrical damage.**
2. Identify, tag or mark each wire to ensure proper connection during installation.
3. Disconnect all connectors and wires from alternator.
4. Loosen belt tension bolt.
5. Loosen alternator pivot bolt.
6. Slip drive belt off alternator pulley, remove all attaching bolts and carefully remove alternator from engine.

---

### Alternator Installation

---

**IMPORTANT:** Some units may require reusing pulley, fan and/or condenser from original unit.

**If required:**

1. Remove fan, pulley, hardware and/or condenser from original unit.
2. Install fan, pulley, hardware and/or condenser on replacement unit. Torque pulley nut to vehicle manufacturer's specification. **WARNING:** Inspect pulley, fan mounting and spacing carefully. Incorrect installation may result in personal injury and/or vehicle damage.

**NOTE:** Replacement unit may not be supplied with rotor shaft key way—**KEY WAYS ARE NOT CRITICAL.**

For proper pulley & fan performance, **PROPER TORQUE ON PULLEY NUT IS CRITICAL.**

1. Charge battery, clean both battery terminals, inspect and clean battery cables and inspect alternator drive belt for cracking or glazing. Replace any or all of these parts if necessary.  
**WARNING:** Failure to follow above steps lead to the most common cause of alternator failure and charging system malfunction.
2. Install the replacement alternator on mounting brackets and loosely install mounting bolts.
3. Place alternator drive belt on alternator pulley. Check to insure proper drive belt alignment.
4. Reconnect all electrical connections to the proper terminals.  
**NOTE:** Some Bosch replacement units may require a wiring connector adapter to allow completion of wiring. This connector is included with appropriate units.
5. Adjust belt to correct tension and tighten alternator mounting bolts. Follow manufacturers specifications for belt tension and mounting bolt torque values.
6. Reconnect negative battery cable.

### Alternator Facts

- Battery must be fully charged to ensure that the charging system will operate properly.
  - Wiring harness plug terminals should be clean of corrosion and fit tightly. Corroded terminals **can** cause alternator failure.
  - Never try to polarize an alternator. Attempting to do so can damage the unit.
-

## Troubleshooting Guide

### Starter Installation Procedures

**IMPORTANT:** Before installation of replacement starter, follow diagnostic guide on next page to ensure necessity for starter replacement.

---

#### Starter Removal

---

1. Disconnect negative battery cable.  
**NOTE: Failure to do so may result in electrical damage.**
2. Remove any dust or debris shields shrouding the starter.
3. Identify, tag or mark each wire to ensure proper connection during installation.
4. Disconnect all connectors and wires from starter.
5. Loosen the starter mounting bolts. Check for location of shims, support brackets and heat shields, if equipped, for correct re-positioning upon installation.
6. Support starter. Remove mounting bolts and nuts and remove the old starter. Tilt or rotate unit to clear flywheel.  
**CAUTION: Starter is heavy; remove with care to avoid injury.**
7. Rotate engine slowly to inspect flywheel and ring gear for warpage or damaged gear teeth. Replace if necessary. Check bell housing bolts for proper tightness.

---

#### Starter Installation

---

1. Charge battery, clean both battery terminals, inspect and clean battery cables and inspect starter drive belt for cracking or glazing. Replace any or all of these parts if necessary.
2. Install the replacement starter with original mounting hardware. Replace all shims, support brackets, and heat shields (if equipped) in proper position. Torque all bolts and nuts to manufacturer's specifications.
3. Reconnect all electrical connections at starter to proper terminals. Wire connections must be clean and tight. Replace all dust and debris shields.

**APPLICATION NOTICE:** The solenoid terminals on this starter may be different from the terminals attached to the wiring harness of the vehicle. The appropriate terminal ends are included with this starter so that the proper connection can be made. If necessary, clip original terminals from wiring harness of the vehicle and crimp or solder the appropriate terminal (included) in its place.





4. Reconnect negative battery cable at battery.
-

**Alternators & Starters**

	BOSCH	CHRYSLER	DELCO	DUCELLIER (PARIS RHONE)	FORD	HITACHI
Positive (+)	B+, Bat			B+	Bat, B+	
Negative (-)	D-			D-		
Sense (+)			2, S	+	A	S
Ignition (+)	R		I, IG			R, IG
Stator	W		P, R	+	Stat, S	N
Indicator	D+, L		1	L		L
Field	DF	F(1), F(2), F	F	D+, D-	FLD, F	F
Computer			F			
Lamp			L		I	
Not Used			D			D

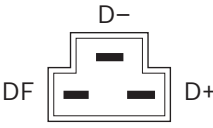
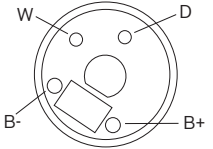
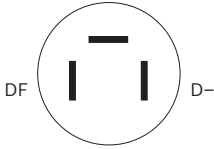
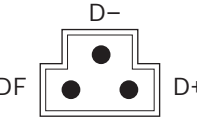
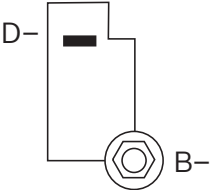
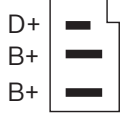
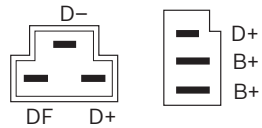
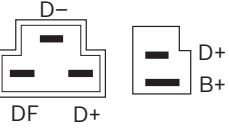
	LUCAS	MANDO	MARELLI	MITSUBISHI	MOTOROLLA	NIPPONDENSO	SEV MARCHAL
Positive (+)	B+			A	BAT		B+
Negative (-)	B-			E	D-	E	D-
Sense (+)	S	S		S, A		S	
Ignition (+)		R		R, IG, D		IG, R	
Stator		P		N, P		N, P	
Indicator	D+	L	30, D+	L	D+	L	61, D+
Field			67	F	DF	F	DF
Computer				C, G, Fr		C, FR	
Lamp				I			
Not Used				D		D	

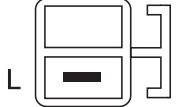

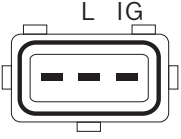
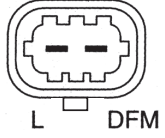
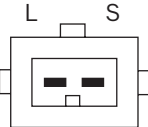
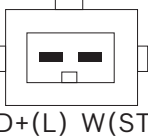
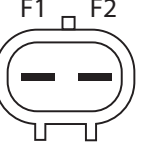
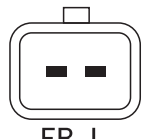
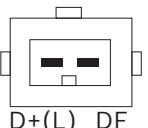
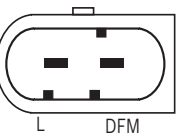
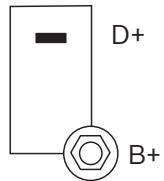
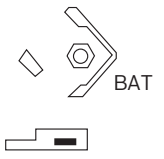
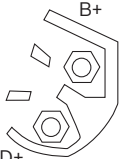
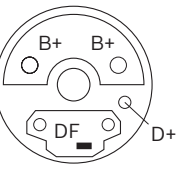
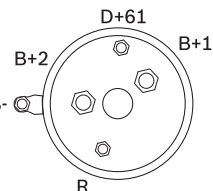

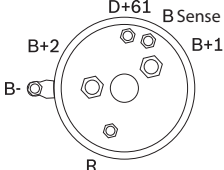
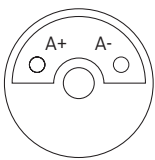
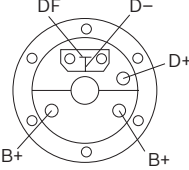
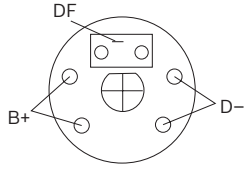
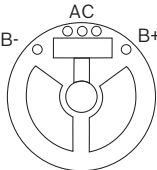
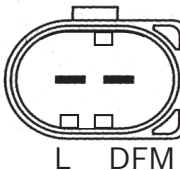
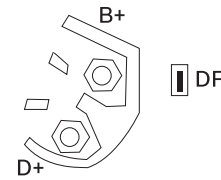
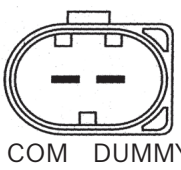
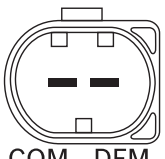
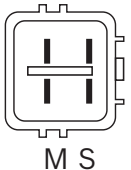
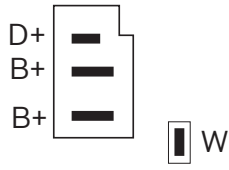
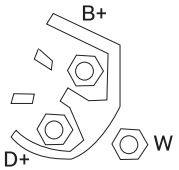
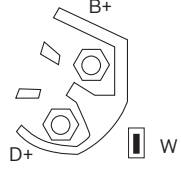
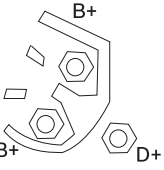
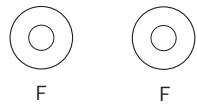
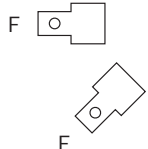
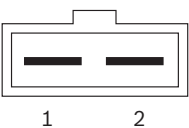
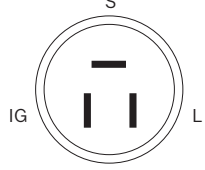
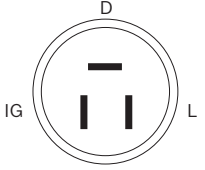
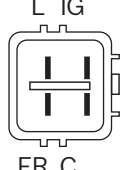

# Voltage Regulator Plug Identification



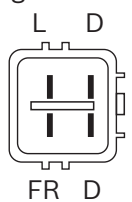
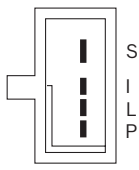
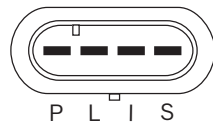
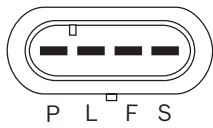
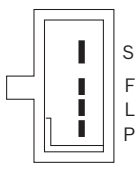
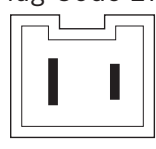
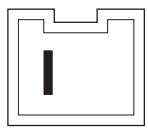
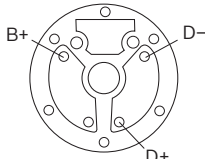

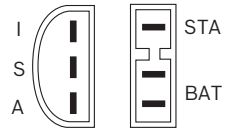
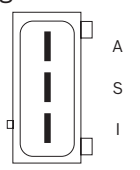
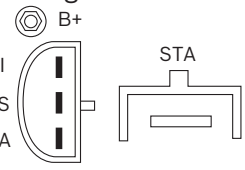

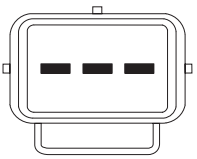
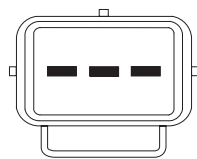
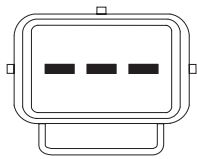
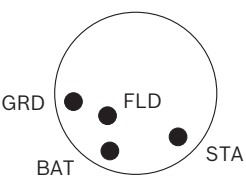

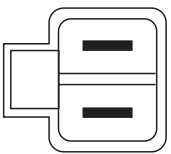
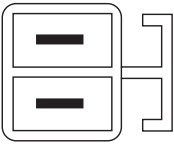
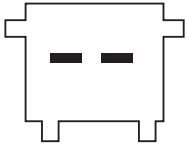

BOSCH			
<p>Plug Code 100</p>  <p>Reg. Type: ER</p>	<p>Plug Code 100W</p>  <p>Reg. Type: ER</p>	<p>Plug Code 101</p>  <p>Reg. Type: ER</p>	<p>Plug Code 102</p>  <p>Reg. Type: ER</p>
<p>Plug Code 109</p>  <p>Reg. Type: ER</p>	<p>Plug Code 110</p>  <p>Reg. Type: IR</p>	<p>Plug Code 111</p>  <p>Reg. Type: ER</p>	<p>Plug Code 113</p>  <p>Reg. Type: ER</p>
<p>Plug Code 192</p>  <p>Reg. Type: IR</p>	<p>Plug Code 304</p>  <p>Reg. Type: IR</p>	<p>Plug Code 320</p>  <p>Reg. Type: ER</p>	<p>Plug Code 335</p>  <p>Reg. Type: IR</p>
<p>Plug Code 346</p>  <p>Reg. Type: ER</p>	<p>Plug Code 360</p>  <p>Reg. Type: IR</p>	<p>Plug Code 361</p>  <p>Reg. Type: IR</p>	<p>Plug Code 363</p>  <p>Reg. Type: ER</p>
<p>Plug Code 365</p>  <p>Reg. Type: IR</p>	<p>Plug Code 366</p>  <p>Reg. Type: IR</p>	<p>Plug Code 367</p>  <p>Reg. Type: IR</p>	<p>Plug Code 371</p>  <p>Reg. Type: ER</p>
<p>Plug Code 380</p>  <p>Reg. Type: IR</p>	<p>Plug Code 381</p>  <p>Reg. Type: IR</p>	<p>Plug Code 400</p>  <p>Reg. Type: ER</p>	<p>Plug Code 401</p>  <p>Reg. Type: IR</p>

BOSCH (cont'd)			
<p>Plug Code 402</p>  <p>Reg. Type: IR</p>	<p>Plug Code 403</p>  <p>Reg. Type: ER</p>	<p>Plug Code 406</p>  <p>Reg. Type: ER</p>	<p>Plug Code 407</p>  <p>Reg. Type: ER</p>
<p>Plug Code 422</p>  <p>Reg. Type: ER</p>	<p>Plug Code 454</p>  <p>Reg. Type: ER</p>	<p>Plug Code 459</p>  <p>Reg. Type: IR</p>	<p>Plug Code 463</p>  <p>Reg. Type: IR</p>
<p>Plug Code 478</p>  <p>Reg. Type: IR</p>	<p>Plug Code 917</p>  <p>Reg. Type: IR</p>	<p>Plug Code 1101</p>  <p>Reg. Type: IR</p>	<p>Plug Code 3811</p>  <p>Reg. Type: IR</p>
<p>Plug Code 3812</p>  <p>Reg. Type: IR</p>	<p>Plug Code 3813</p>  <p>Reg. Type: IR</p>		
CHRYSLER			
<p>Plug Code 320</p>  <p>Reg. Type: ER</p>	<p>Plug Code 375</p>  <p>Reg. Type: ER</p>		
DELCO			
<p>Plug Code 151</p>  <p>Reg. Type: IR</p>	<p>Plug Code 280</p>  <p>Reg. Type: ER</p>	<p>Plug Code 282</p>  <p>Reg. Type: ER</p>	<p>Plug Code 296</p>  <p>Reg. Type: IR</p>

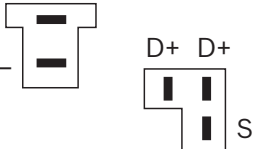

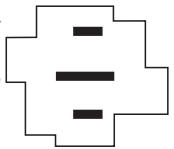
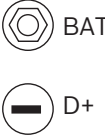
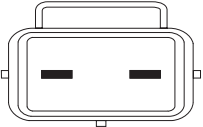
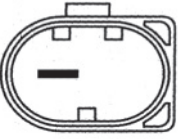

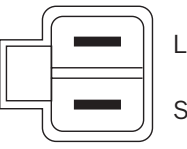
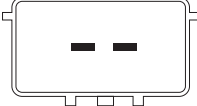
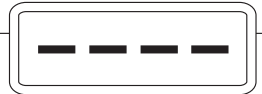
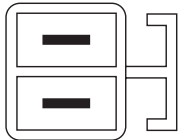







# Voltage Regulator Plug Identification

DELCO (cont'd)			
<p>Plug Code 297</p>  <p>Reg. Type: IR</p>	<p>Plug Code 310</p>  <p>Reg. Type: IR</p>	<p>Plug Code 313</p>  <p>Reg. Type: ER</p>	<p>Plug Code 314</p>  <p>Reg. Type: ER</p>
<p>Plug Code 3091</p>  <p>Reg. Type: IR</p>			
DUCELLIER (Paris-Rhone)			
<p>Plug Code 270</p>  <p>Reg. Type: IR</p>	<p>Plug Code 272</p>  <p>Reg. Type: IR</p>	<p>Plug Code 405</p>  <p>Reg. Type: ER</p>	
FORD			
<p>Plug Code 194</p>  <p>Reg. Type: ER</p>	<p>Plug Code 330</p>  <p>Reg. Type: IR</p>	<p>Plug Code 332</p>  <p>Reg. Type: IR</p>	<p>Plug Code 333</p>  <p>Reg. Type: IR</p>
<p>Plug Code 334</p>  <p>Reg. Type: IR</p>	<p>Plug Code 336</p> <p>L/IG D (+)</p>  <p>Reg. Type: IR</p>	<p>Plug Code 337</p> <p>(+) FR SIG</p>  <p>Reg. Type: IR</p>	<p>Plug Code 338</p> <p>L/IG FR (+)</p>  <p>Reg. Type: IR</p>
<p>Plug Code 410</p>  <p>Reg. Type: ER</p>	<p>Plug Code 901</p>  <p>Reg. Type: IR</p>		

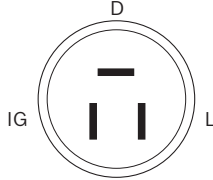
HITACHI			
Plug Code 190 N F  Reg. Type: ER	Plug Code 191 S L  Reg. Type: IR	Plug Code 221 L S (Diesel)  Reg. Type: IR	Plug Code 300  L S Reg. Type: IR
Plug Code 303 D P  Reg. Type: IR	Plug Code 305 L S  Reg. Type: IR	Plug Code 350 S L IG  Reg. Type: IR	Plug Code 351 S IG D L  Reg. Type: IR
LUCAS			
Plug Code 107 B+ B- D+ D+ S  Reg. Type: IR	Plug Code 110 D+ B+ B+  Reg. Type: IR	Plug Code 120 D+ B+ S  Reg. Type: IR	Plug Code 373  BAT D+ Reg. Type: IR
Plug Code 434  L IG Reg. Type: IR	Plug Code 465  COM (BSS) Reg. Type: IR		
MANDO			
Plug Code 192 R L  Reg. Type: IR	Plug Code 300  L S Reg. Type: IR	Plug Code 306  L S Reg. Type: IR	Plug Code 307 FLS G  Reg. Type: IR
Plug Code 909 S L  Reg. Type: IR P	Plug Code 1911 S L  Reg. Type: IR P		

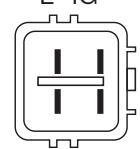
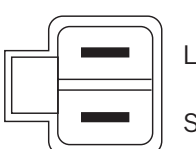
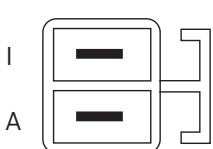
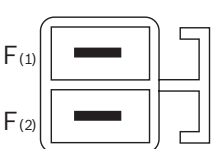
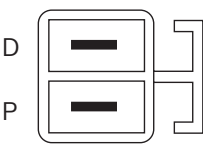
# Voltage Regulator Plug Identification

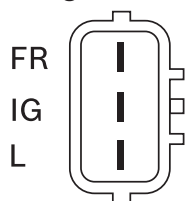
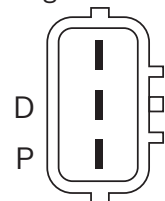
## MITSUBISHI

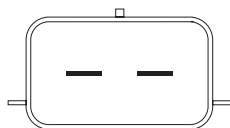
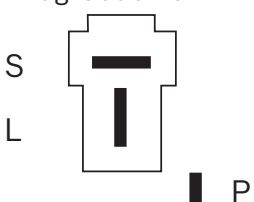
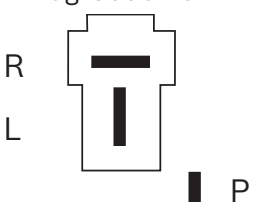
<p>Plug Code 130</p>  <p>Reg. Type: IR</p>	<p>Plug Code 190</p>  <p>Reg. Type: IR</p>	<p>Plug Code 191</p>  <p>Reg. Type: IR</p>	<p>Plug Code 192</p>  <p>Reg. Type: IR</p>
<p>Plug Code 193</p>  <p>Reg. Type: IR</p>	<p>Plug Code 282</p>  <p>Reg. Type: IR</p>	<p>Plug Code 292</p>  <p>Reg. Type: IR</p>	<p>Plug Code 294</p>  <p>Reg. Type: IR</p>
<p>Plug Code 296</p>  <p>Reg. Type: IR</p>	<p>Plug Code 300</p>  <p>Reg. Type: IR</p>	<p>Plug Code 301</p>  <p>Reg. Type: IR</p>	<p>Plug Code 302</p>  <p>Reg. Type: ER</p>
<p>Plug Code 303</p>  <p>Reg. Type: IR</p>	<p>Plug Code 307</p>  <p>Reg. Type: IR</p>	<p>Plug Code 316</p>  <p>Reg. Type: IR</p>	<p>Plug Code 325</p>  <p>Reg. Type: IR</p>
<p>Plug Code 334</p>  <p>Reg. Type: ER</p>	<p>Plug Code 362</p>  <p>Reg. Type: IR</p>	<p>Plug Code 1911</p>  <p>Reg. Type: IR</p>	<p>Plug Code 1921</p>  <p>Reg. Type: IR</p>

## MOTOROLA

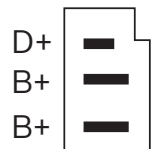
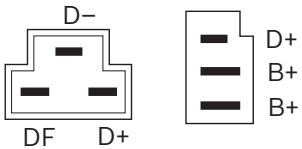
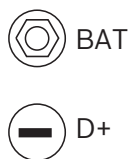
<p>Plug Code 110</p>  <p>Reg. Type: IR</p>	<p>Plug Code 111</p>  <p>Reg. Type: ER</p>	<p>Plug Code 373</p>  <p>Reg. Type: IR</p>	
---	---	---	--

NIPPONDENSO			
<p>Plug Code 140</p> <p>Reg. Type: IR</p>	<p>Plug Code 192</p> <p>Reg. Type: IR</p>	<p>Plug Code 230</p> <p>Reg. Type: IR</p>	<p>Plug Code 231</p> <p>Reg. Type: IR</p>
<p>Plug Code 240</p> <p>Reg. Type: IR</p>	<p>Plug Code 241</p> <p>Reg. Type: IR</p>	<p>Plug Code 250</p> <p>Reg. Type: IR</p>	<p>Plug Code 251</p> <p>Reg. Type: IR</p>
<p>Plug Code 260</p> <p>Reg. Type: IR</p>	<p>Plug Code 261</p> <p>Reg. Type: IR</p>	<p>Plug Code 280</p> <p>Reg. Type: IR</p>	<p>Plug Code 282</p> <p>Reg. Type: IR</p>
<p>Plug Code 284</p> <p>Reg. Type: IR</p>	<p>Plug Code 285</p> <p>Reg. Type: IR</p>	<p>Plug Code 286</p> <p>Reg. Type: IR</p>	<p>Plug Code 290</p> <p>Reg. Type: IR</p>
<p>Plug Code 292</p> <p>Reg. Type: IR</p>	<p>Plug Code 294</p> <p>Reg. Type: IR</p>	<p>Plug Code 295</p> <p>Reg. Type: IR</p>	<p>Plug Code 296</p> <p>Reg. Type: IR</p>
<p>Plug Code 312</p> <p>Reg. Type: IR</p>	<p>Plug Code 317</p> <p>Reg. Type: IR</p>	<p>Plug Code 318</p> <p>Reg. Type: IR</p>	<p>Plug Code 319</p> <p>Reg. Type: IR</p>

# Voltage Regulator Plug Identification

## NIPPONDENSO (cont'd)

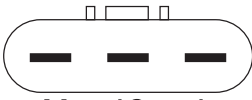
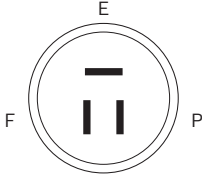
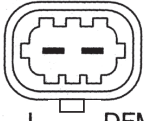
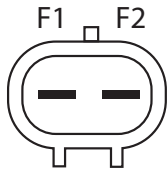
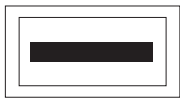
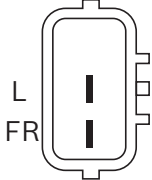
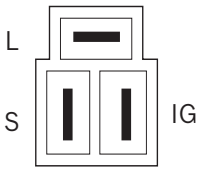
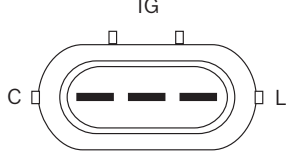
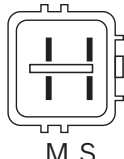
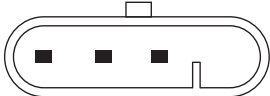
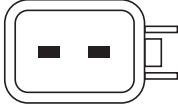
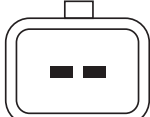
<p>Plug Code 321</p>  <p>M IG L</p> <p>Reg. Type: IR</p>	<p>Plug Code 340</p>  <p>E</p> <p>F P</p> <p>Reg. Type: IR</p>	<p>Plug Code 346</p>  <p>L DFM</p> <p>Reg. Type: ER</p>	<p>Plug Code 363</p>  <p>F1 F2</p> <p>Reg. Type: IR</p>
<p>Plug Code 370</p>  <p>D+ (L)</p> <p>Reg. Type: IR</p>	<p>Plug Code 427</p>  <p>L FR</p> <p>Reg. Type: IR</p>	<p>Plug Code 469</p>  <p>L S IG</p> <p>Reg. Type: IR</p>	<p>Plug Code 915</p>  <p>IG</p> <p>C L</p> <p>Reg. Type: IR</p>
<p>Plug Code 917</p>  <p>L IG</p> <p>M S</p> <p>Reg. Type: IR</p>	<p>Plug Code 1003</p>  <p>S F L</p> <p>Reg. Type: IR</p>	<p>Plug Code 1008</p>  <p>F1 F2</p> <p>Reg. Type: IR</p>	<p>Plug Code 1009</p>  <p>COM NC</p> <p>Reg. Type: IR</p>

## VALEO

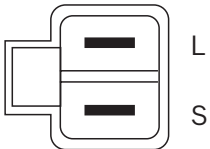
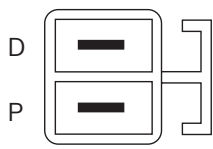
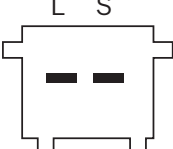
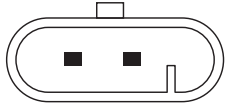
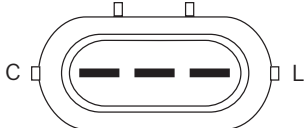
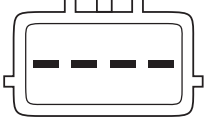
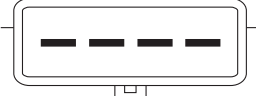
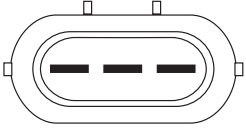
<p>Plug Code 300</p>  <p>L S</p> <p>Reg. Type: IR</p>	<p>Plug Code 303</p>  <p>D P</p> <p>Reg. Type: IR</p>	<p>Plug Code 305</p>  <p>L S</p> <p>Reg. Type: IR</p>	<p>Plug Code 323</p>  <p>F L</p> <p>Reg. Type: IR</p>
<p>Plug Code 915</p>  <p>IG</p> <p>C L</p> <p>Reg. Type: IR</p>	<p>Plug Code 1006</p>  <p>L F</p> <p>Reg. Type: IR</p>	<p>Plug Code 1007</p>  <p>F R L</p> <p>Reg. Type: IR</p>	<p>Plug Code 4271</p>  <p>S L Fr</p> <p>Reg. Type: IR</p>