



How to Bench Bleed a Step Bore Master Cylinder

It is difficult to bleed all of the air out of this style of master cylinder after it is installed on the vehicle. However, it is very easy to bleed the unit before it is installed following the steps below.

NEW AND IMPROVED MASTER CYLINDER BENCH BLEEDING PROCEDURE

1. Transfer proportioning valves, switches or other components to the replacement master cylinder. (Illustration 1)
2. Tighten bleeder plugs into ports (bleeder plugs may be in parts kit or reservoir).
3. Support the master cylinder on a workbench in a level position. Never clamp onto the body of the master cylinder. (Illustration 2)
NOTE: Units with remote reservoir should be bled on the vehicle. It is **VERY IMPORTANT** that the body of the master cylinder be kept level during on-vehicle bleeding.
4. Fill reservoir half-way or until reservoir ports are covered. Always use new brake fluid from a sealed container as specified by vehicle manufacture.
5. Install reservoir cap so brake fluid does not spray from reservoir during bleeding process.
6. Using a blunt tool or dowel (brake pedal if mounted in vehicle). **SLOWLY** press in and release the master cylinder piston using shortstrokes of 3/4" to 1" **NEVER STROKE PISTON MORE THAN 1"**. Repeat this step until resistance to piston movement is firm and less than 1/8".

IMPORTANT NOTE: On step-bore quick take-up master cylinders, **wait 20 seconds between strokes**. This will allow air trapped in valve to rise into reservoir. **MASTER CYLINDER BODY MUST BE LEVEL.**

7. Install master cylinder on vehicle. **DO NOT** remove bleeder plugs until master cylinder is installed, this prevents air from entering the unit and brake fluid leaking out.
8. Remove one bleeder plug at a time from the master cylinder and connect the proper brake line to that port. Repeat this step for remaining brake line ports. Be sure fluid level is maintained during installation of brake lines and that all fittings are clean before installation. Bleed brake system according to vehicle manufacturer's procedures and specifications.
9. Verify proper pedal action before moving vehicle. Do not road test vehicle until correct pedal feel and travel are obtained.

NOTE: If firm brake pedal action results using bleeder plugs, but becomes soft after installation in vehicle, the problem is not thereplacement master cylinder.

ILLUSTRATION 1
TYPICAL INSTALLATION WITH SWITCH & PROPORTIONING VALVES

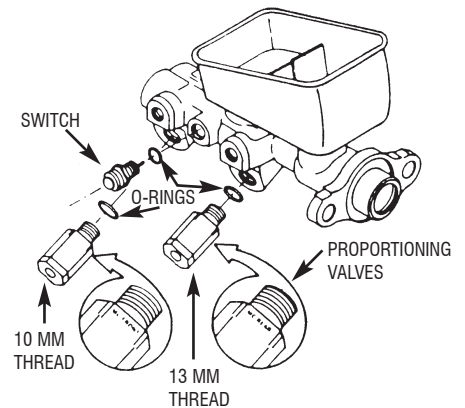
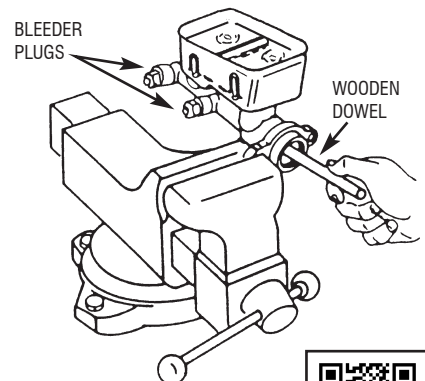

ILLUSTRATION 2



SCAN FOR TECH TIP VIDEO

