

## WATER PUMP GASKET

6.9l Engine use 1 1/4" bolts here with flat washers.

7.3l Engine use 1 1/2" bolts here with flat washers.

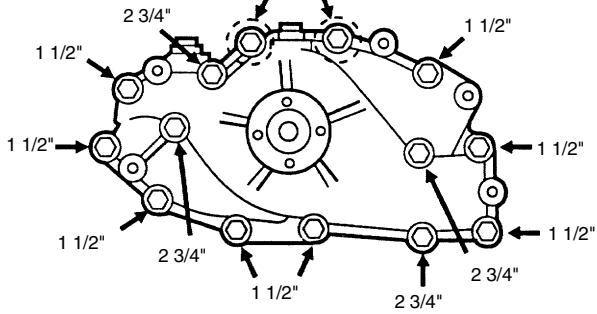

Water Pump Mounting Bolt Lengths and Locations

The 6.9l and 7.3l engines have different length water pump bolts (see illustration for proper installation).

6.9l Engines Uses 1 1/4" bolts with flat washers.

7.3l Engines Uses 1 1/2" bolts with flat washers.

**TEST RUN ENGINE.** Check all mating areas thoroughly to determine that all seals hold during operation.

# FIT<sup>®</sup>

## FEL-PRO INSTALLATION TIPS

### HEAD GASKET

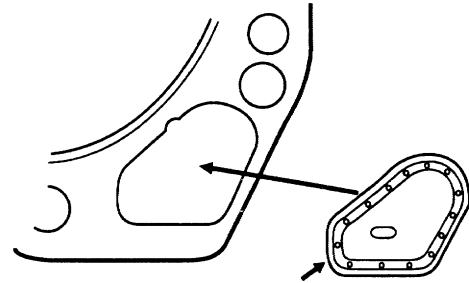

Steel Cored Coolant Grommet

**ATTACH AND ALIGN GASKET(S) FOLLOWING ANY DIRECTIONAL MARKINGS SHOWN ON THE GASKET.** If no markings exist, simply install the gasket by matching the gasket to engine deck surface.

**FIBER FACED GASKET(S)** are to be installed dry. **METAL FACED GASKET(S)** required a thin even coat of sealer, to be applied to the metal side (s) of the gasket.

---

**NOW INSTALL** the 2 steel cored coolant grommets (see illustration).

---

-Continued-

## WATER PUMP GASKET

6.9l Engine use 1 1/4" bolts here with flat washers.

7.3l Engine use 1 1/2" bolts here with flat washers.

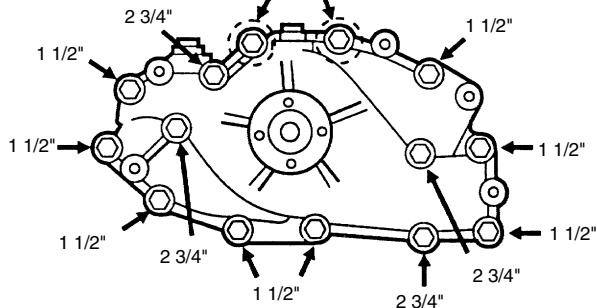

Water Pump Mounting Bolt Lengths and Locations

The 6.9l and 7.3l engines have different length water pump bolts (see illustration for proper installation).

6.9l Engines Uses 1 1/4" bolts with flat washers.

7.3l Engines Uses 1 1/2" bolts with flat washers.

**TEST RUN ENGINE.** Check all mating areas thoroughly to determine that all seals hold during operation.

# FIT<sup>®</sup>

## FEL-PRO INSTALLATION TIPS

### HEAD GASKET

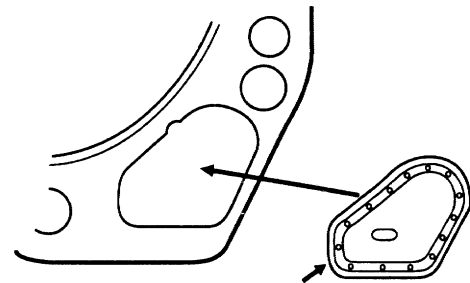

Steel Cored Coolant Grommet

**ATTACH AND ALIGN GASKET(S) FOLLOWING ANY DIRECTIONAL MARKINGS SHOWN ON THE GASKET.** If no markings exist, simply install the gasket by matching the gasket to engine deck surface.

**FIBER FACED GASKET(S)** are to be installed dry. **METAL FACED GASKET(S)** required a thin even coat of sealer, to be applied to the metal side (s) of the gasket.

---

**NOW INSTALL** the 2 steel cored coolant grommets (see illustration).

---

-Continued-

## WATER PUMP GASKET

6.9l Engine use 1 1/4" bolts here with flat washers.

7.3l Engine use 1 1/2" bolts here with flat washers.

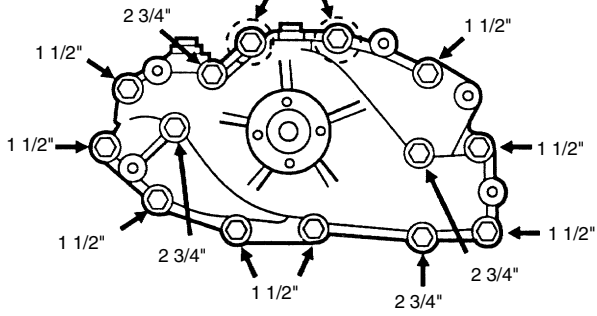

Water Pump Mounting Bolt Lengths and Locations

The 6.9l and 7.3l engines have different length water pump bolts (see illustration for proper installation).

6.9l Engines Uses 1 1/4" bolts with flat washers.

7.3l Engines Uses 1 1/2" bolts with flat washers.

**TEST RUN ENGINE.** Check all mating areas thoroughly to determine that all seals hold during operation.

# FIT®

## FEL-PRO INSTALLATION TIPS

### HEAD GASKET

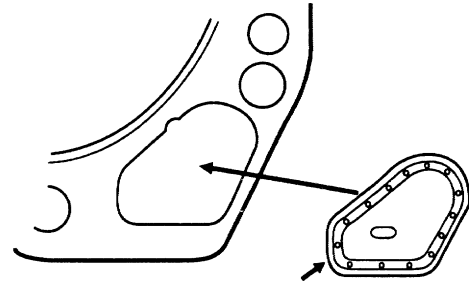

Steel Cored Coolant Grommet

**ATTACH AND ALIGN GASKET(S) FOLLOWING ANY DIRECTIONAL MARKINGS SHOWN ON THE GASKET.** If no markings exist, simply install the gasket by matching the gasket to engine deck surface.

**FIBER FACED GASKET(S)** are to be installed dry. **METAL FACED GASKET(S)** required a thin even coat of sealer, to be applied to the metal side (s) of the gasket.

---

**NOW INSTALL** the 2 steel cored coolant grommets (see illustration).

---

-Continued-

## WATER PUMP GASKET

6.9l Engine use 1 1/4" bolts here with flat washers.

7.3l Engine use 1 1/2" bolts here with flat washers.

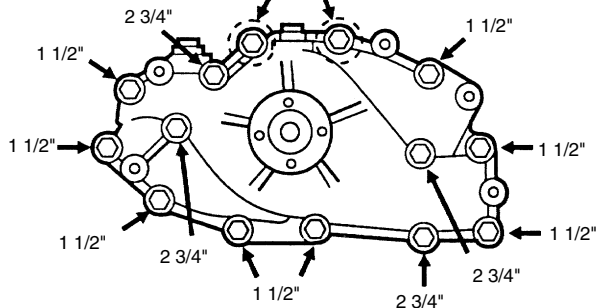

Water Pump Mounting Bolt Lengths and Locations

The 6.9l and 7.3l engines have different length water pump bolts (see illustration for proper installation).

6.9l Engines Uses 1 1/4" bolts with flat washers.

7.3l Engines Uses 1 1/2" bolts with flat washers.

**TEST RUN ENGINE.** Check all mating areas thoroughly to determine that all seals hold during operation.

# FIT®

## FEL-PRO INSTALLATION TIPS

### HEAD GASKET

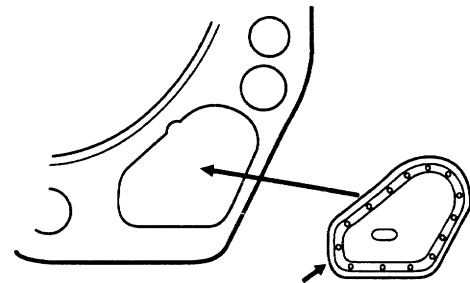

Steel Cored Coolant Grommet

**ATTACH AND ALIGN GASKET(S) FOLLOWING ANY DIRECTIONAL MARKINGS SHOWN ON THE GASKET.** If no markings exist, simply install the gasket by matching the gasket to engine deck surface.

**FIBER FACED GASKET(S)** are to be installed dry. **METAL FACED GASKET(S)** required a thin even coat of sealer, to be applied to the metal side (s) of the gasket.

---

**NOW INSTALL** the 2 steel cored coolant grommets (see illustration).

---

-Continued-