

INTAKE MANIFOLD GASKET



Open Center Port

This set contains 2 manifold gaskets with the center port open, and 1 stainless steel restrictor assembly attached to one of these gaskets. Install open center port gasket on the left side and install the restricted center port gasket on the right side.

Use manifold gasket(s) with open center port(s) as supplied in this set or with restrictor assemblies in place as noted.

■ - Restricted □ - Open

		Center Ports:		Right	Left
Passenger Car					
396 Eng.					
1965-70	Exc. Special Hi-Perf. and Heavy Duty		□	□	
400 Eng.					
1970-72	4 Barrel, Big Block		□	□	
427 Eng.					
1966-69	Exc. Special Hi-Perf. and Heavy Duty		□	□	
454 Eng.					
1975-76	Exc. Heavy Duty		□	□	
1973-74	Exc. Heavy Duty		■	□	
1970-72	Exc. Special Hi-Perf. and Heavy Duty		□	□	
Truck					
366, 396, 427 Eng.					
1966-85		□	□	
400 Eng.					
1971-72	4 Barrel, Big Block		□	□	
454 Eng.					
1979		□	□	
1975-78	Exc. California		■	□	
	California		□	□	
1973-74	Exc. EGR		□	□	
	EGR		■	□	
1971-72		□	□	

RESTRICTED PORT GASKET:

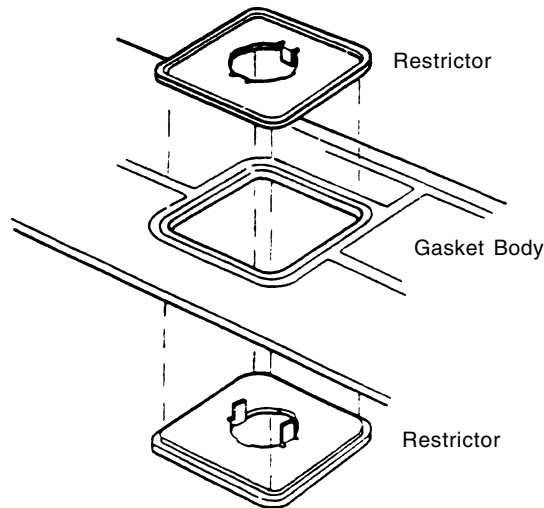

PLACE 1 RESTRICTOR HALF - with prongs up - on the workbench.

POSITION THE CENTER PORT OF THE MANIFOLD GASKET over the restrictor half.

PLACE THE OTHER RESTRICTOR HALF OVER the gasket's center port.

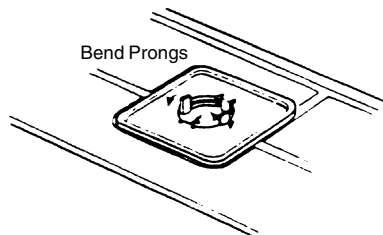

BEND THE 2 PRONGS OF THE LOWER RESTRICTOR HALF OUTWARD over the outer edge of the upper restrictor half using a blunt tool. Make certain the prongs are pressed down tightly so that the restrictor assembly is held securely in the gasket body. Turn the gasket over and repeat the prong bending operation with the other restrictor half.

IMPORTANT: When properly installed, the outer edge of the upper and lower restrictor halves will overlap the gasket body around the center port. Failure to do so may cause restrictor to slide out of position.

CLEAN MATING SURFACES of all foreign material including old gaskets, RTV and oil. You may wish to use a degreaser.

CHECK MANIFOLD CASTINGS for flatness of gasket surface. Resurface or replace if severely distorted or corroded.

ATTACH AND ALIGN END SEALS. Apply quick-drying adhesive sparingly to cylinder block. Mount end seals. **Allow time adhesive to set.** Test for slippage with light pressure. If seals move, allow more time.

ATTACH AND ALIGN GASKET(S) TO CYLINDER HEAD(S). Apply quick drying adhesive sparingly in several places on the cylinder heads. Mount gasket(s) on cylinder head(s). **Allow time for adhesive to set.** Test for slippage with light pressure. If gasket moves, allow more time.

PRIOR TO REINSTALLING INTAKE MANIFOLD apply a small dab of RTV Black silicone sealer to the 4 corner intersections between the end seals and gaskets.

REINSTALL INTAKE MANIFOLD TO ENGINE. Torque securely to OEM specifications

INTAKE MANIFOLD GASKET



Open Center Port

This set contains 2 manifold gaskets with the center port open, and 1 stainless steel restrictor assembly attached to one of these gaskets. Install open center port gasket on the left side and install the restricted center port gasket on the right side.

Use manifold gasket(s) with open center port(s) as supplied in this set or with restrictor assemblies in place as noted.

■ - Restricted □ - Open

		Center Ports:	Right	Left
Passenger Car				
396 Eng.				
1965-70	Exc. Special Hi-Perf. and Heavy Duty	□	□	
400 Eng.				
1970-72	4 Barrel, Big Block	□	□	
427 Eng.				
1966-69	Exc. Special Hi-Perf. and Heavy Duty	□	□	
454 Eng.				
1975-76	Exc. Heavy Duty	□	□	
1973-74	Exc. Heavy Duty	■	□	
1970-72	Exc. Special Hi-Perf. and Heavy Duty	□	□	
Truck				
366, 396, 427 Eng.				
1966-85	□	□	
400 Eng.				
1971-72	4 Barrel, Big Block	□	□	
454 Eng.				
1979	□	□	
1975-78	Exc. California	■	□	
	California	□	□	
1973-74	Exc. EGR	□	□	
	EGR	■	□	
1971-72	□	□	

RESTRICTED PORT GASKET:

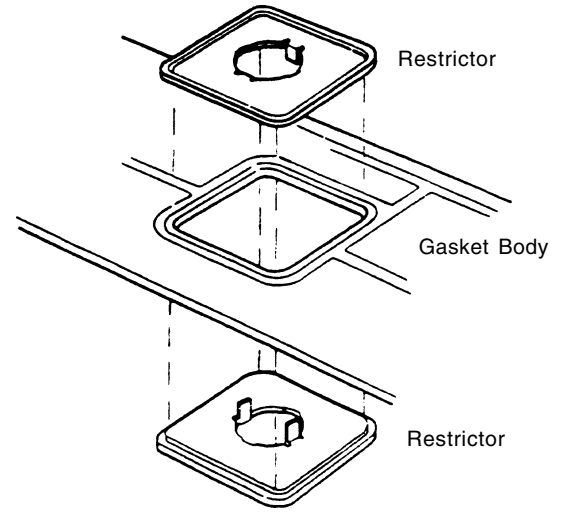

PLACE 1 RESTRICTOR HALF - with prongs up - on the workbench.

POSITION THE CENTER PORT OF THE MANIFOLD GASKET over the restrictor half.

PLACE THE OTHER RESTRICTOR HALF OVER the gasket's center port.

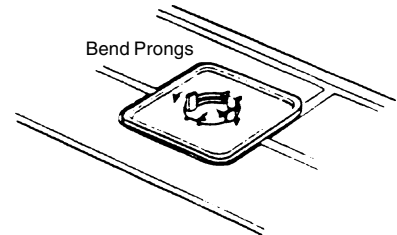

BEND THE 2 PRONGS OF THE LOWER RESTRICTOR HALF OUTWARD over the outer edge of the upper restrictor half using a blunt tool. Make certain the prongs are pressed down tightly so that the restrictor assembly is held securely in the gasket body. Turn the gasket over and repeat the prong bending operation with the other restrictor half.

IMPORTANT: When properly installed, the outer edge of the upper and lower restrictor halves will overlap the gasket body around the center port. Failure to do so may cause restrictor to slide out of position.

CLEAN MATING SURFACES of all foreign material including old gaskets, RTV and oil. You may wish to use a degreaser.

CHECK MANIFOLD CASTINGS for flatness of gasket surface. Resurface or replace if severely distorted or corroded.

ATTACH AND ALIGN END SEALS. Apply quick-drying adhesive sparingly to cylinder block. Mount end seals. **Allow time adhesive to set.** Test for slippage with light pressure. If seals move, allow more time.

ATTACH AND ALIGN GASKET(S) TO CYLINDER HEAD(S). Apply quick drying adhesive sparingly in several places on the cylinder heads. Mount gasket(s) on cylinder head(s). **Allow time for adhesive to set.** Test for slippage with light pressure. If gasket moves, allow more time.

PRIOR TO REINSTALLING INTAKE MANIFOLD apply a small dab of RTV Black silicone sealer to the 4 corner intersections between the end seals and gaskets.

REINSTALL INTAKE MANIFOLD TO ENGINE. Torque securely to OEM specifications