

PROBLEM *Solver*[™] BULLETIN

Vehicle Shimmy and Wander

www.moogproblemsolver.com

Various Jeep Vehicles

PROBLEM:

Track bar worn and loose at either or both ends

- Vehicle shimmies after hitting a bump.
- Wanders on straight, level road.
- Customer may mention hearing a “clunk” when turning corners.

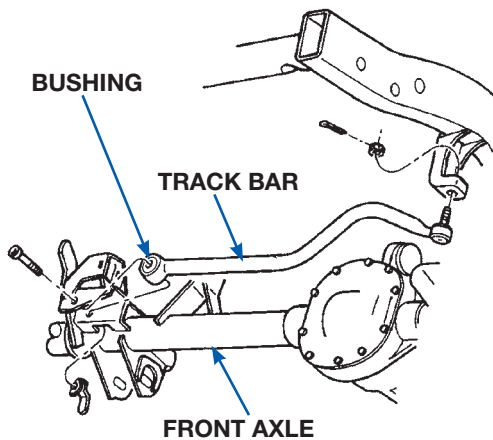

Year	Make/Model	Part Number
TRACK BAR		
1993-1998	Jeep Grand Cherokee 2WD	DS1235
1991-2001	Jeep Cherokee & Comanche 2WD	
1993-1994	Jeep Grand Wagoneer 4WD	
1993-1998	Jeep Grand Cherokee 4WD	
1991-2001	Jeep Cherokee & Comanche 4WD	
1997-2006	Jeep Wrangler 4WD	DS1147
1984-1990	Jeep Wagoneer, Cherokee & Comanche 2WD	
1984-1990	Jeep Wagoneer, Cherokee & Comanche 4WD	
THREE-PIECE BUSHING KIT		
Use in DS1235 or DS1147 applications		K3176

SOLUTION:

MOOG® track bar & three-piece bushing kit



- If loose at ball stud end, where the track bar is attached to vehicle body, a complete replacement is required using the DS1235 or DS1147 as per applications shown. (Includes standard bar-to-axle bushing.)
- If only the bushing end is loose, where the track bar attaches to the axle, a Problem Solver K3176 three-piece bushing kit is available.
 - No need to replace the complete track bar.
 - Bushing replacement does not require track bar removal or special tools.



DS1235/1147
Track Bar

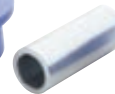
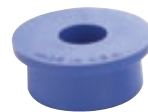

K3176
3-Piece Bushing Kit

K3176
Assembled



THE PROBLEM SOLVER™

