

PTC

Power Train Components, Inc.

PTC and You

Partners for Profit!

Not All Wheel Hub Assemblies Are Created Equal

It's What You Can't See That Separates a Quality Unit from Other Units

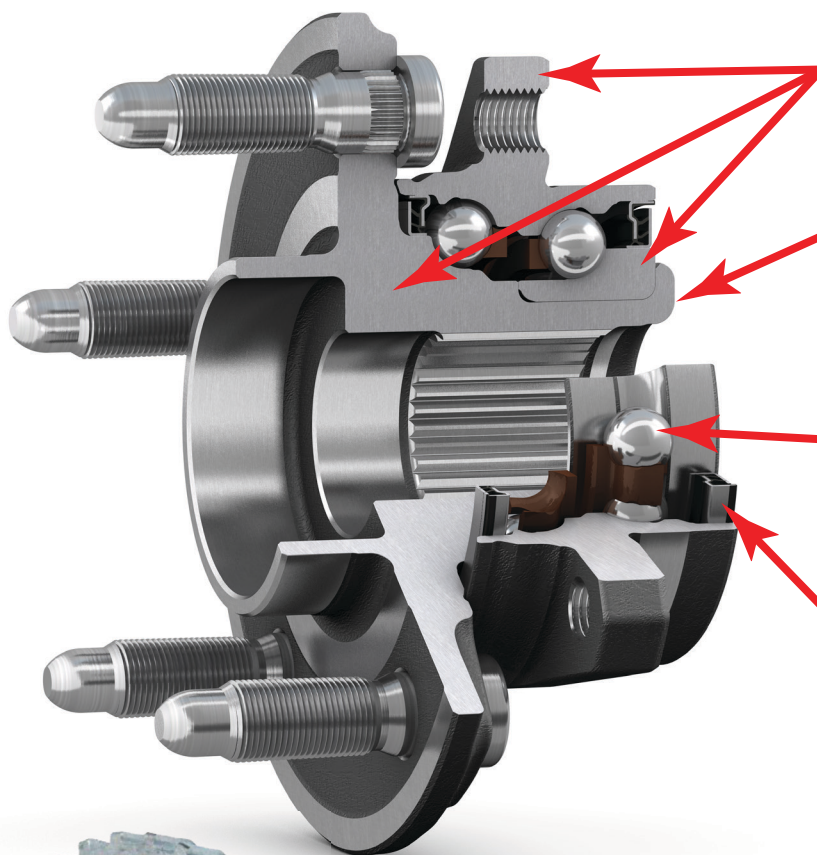

Inner/Outer Ring & Flange

Premium grade high carbon steel is used to provide good mechanical properties and improve bearing performance

Orbital Roll-Formed Design

Applies precise pre-load to enhance performance and decrease failure.
*Nut can no longer be over-tightened (available on select units)

Surface Hardened Bearings

Special surface hardened bearings are highly resistant to premature wear and scratching which improves service life

Waterproof Seal

A special waterproof seal ring with a dustproof structure provides better high temperature and wear resistance

Over 810 SKU's Available, Including First-to-Market Late Model Applications



Premium Casted Metal Tone Ring

OE Style casted metal tone rings have rectangular teeth vs. cheaper pot metal tone rings with rounded teeth. This helps eliminate erratic ABS signals that can cause braking problems.

Premium "Shell" Grease

Premium grade "Shell" grease is used to provide a better lubrication properties to reduce friction and wear over time.

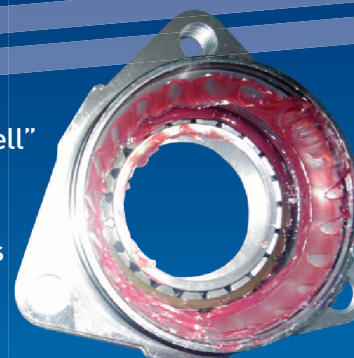

Click Here for a complete list of current Hub Bearing Numbers available. We've got the right product, the right quality and the right price to meet your needs!

Call Us Today at 800.626.8333 to Order Your Needs!