

INSTRUCTION SHEET

MARVEL-SCHEBLER CARBURETOR MODEL-DLTX

GENERAL EXPLODED VIEW

THE GENERAL DESIGN AND PARTS SHOWN WILL VARY TO INDIVIDUAL UNITS COVERED ON THIS INSTRUCTION SHEET

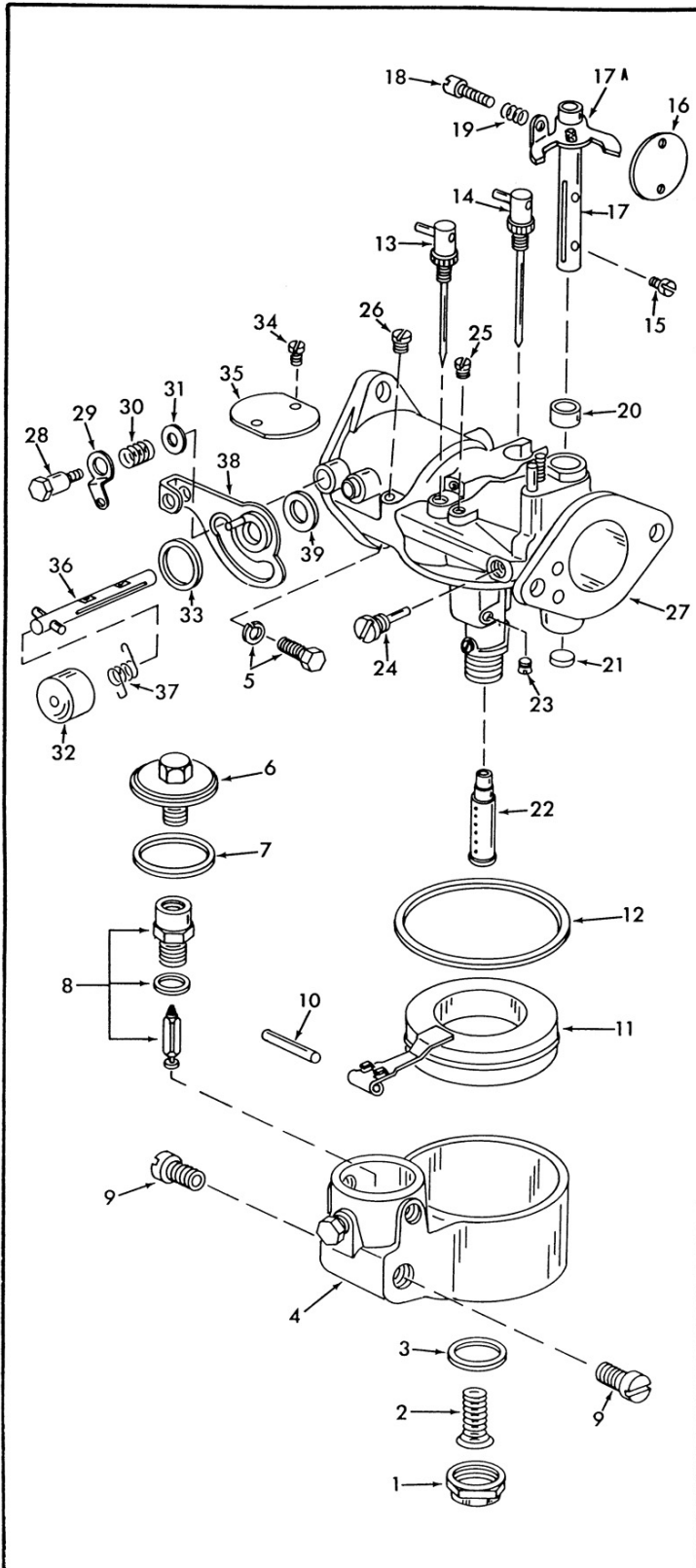

DISASSEMBLY

USE EXPLODED VIEW AS A GUIDE. THE NUMERICAL SEQUENCE MAY GENERALLY BE FOLLOWED TO DISASSEMBLE UNIT FAR ENOUGH TO PERMIT CLEANING AND INSPECTION. NOTE: ON SOME MODELS IT IS NECESSARY TO FIRST REMOVE THROTTLE LEVER (17A) FROM SHAFT BEFORE THROTTLE VALVE (16) CAN BE REMOVED. MAIN NOZZLE (22) CAN BE REMOVED BY INSERTING A SMALL TAPERED PULLER AND LIGHTLY TAPPING OUT OF HOUSING. NUMBERS 28 THRU 39 ARE FOR CARBURETORS DLTX 67-71-72-73 ONLY.

NOMENCLATURE

REF. NO.	REF. NO.
1. NUT-BOWL RETAINING	20. SEAL (FELT)-THROTTLE SHAFT
2. SPRING-NOZZLE RETAINING	21. PLUG-THROTTLE SHAFT HOLE
3. GASKET-BOWL NUT	22. NOZZLE-MAIN
4. BOWL-FLOAT	23. SCREW-DRILL PLUG
5. CAP SCREW & LOCKWASHER-FLANGE	24. PLUG-ECONOMIZER
6. STRAINER ASSEMBLY	25. SCREW-DRILL PLUG
7. GASKET-STRAINER CAP	26. SCREW-DRILL PLUG
8. NEEDLE, SEAT & GASKET ASSY.	27. MAIN BODY ASSY.
9. BEARING SCREW (2)-FLOAT LEVER PIN	
10. PIN-FLOAT LEVER	DLTX 67-71-72-73 CARB. ONLY
11. FLOAT & LEVER ASSEMBLY	28. SCREW-CHOKE LEVER
12. GASKET-BOWL COVER	29. SPRING-DUST COVER
13. NEEDLE ASSY. (BRASS PLATED)-IDLE ADJUSTING	30. SPRING-CHOKE FRICTION
14. NEEDLE ASSY. (CADMIUM PLATED)-POWER ADJUSTING	31. WASHER-CHOKE LEVER SCREW
15. SCREW & LOCKWASHER (2)-THROTTLE VALVE	32. COVER-DUST
16. THROTTLE VALVE	33. GASKET-DUST COVER
17. SHAFT & LEVER ASSY.-THROTTLE	34. SCREW & LOCKWASHER (2)-CHOKE VALVE
18. SCREW-THROTTLE STOP	35. CHOKE VALVE
19. SPRING-THROTTLE STOP SCREW	36. SHAFT-CHOKE
	37. SPRING-CHOKE RETURN
	38. LEVER ASSEMBLY-CHOKE
	39. GASKET-CHOKE LEVER

CLEANING

CLEANING MUST BE DONE WITH CARBURETOR DISASSEMBLED. SOAK PARTS LONG ENOUGH TO SOFTEN AND REMOVE ALL FOREIGN MATERIAL. USE (1) A CARBURETOR CLEANING SOLVENT, (2) LACQUER THINNER, OR (3) DENATURED ALCOHOL. MAKE CERTAIN THE THROTTLE BORE IS FREE OF ALL CARBON AND VARNISH DEPOSITS. RINSE OFF IN SUITABLE SOLVENT. BLOW OUT ALL PASSAGES IN CASTINGS WITH COMPRESSED AIR AND CHECK CAREFULLY TO INSURE THOROUGH CLEANING OF OBSCURE AREAS. CAUTION: DO NOT SOAK RUBBER PARTS OR CORK FLOAT IN CLEANING SOLVENT.

REASSEMBLY

REASSEMBLE IN REVERSE ORDER OF DISASSEMBLY. NOTE SPECIAL INSTRUCTIONS.

SPECIAL INSTRUCTIONS

MAIN NOZZLE (22) - INSTALL NOZZLE THEN TAP BOTTOM OF THE NOZZLE LIGHTLY TO SEAT IN CASTING.

THROTTLE VALVE (16) - INSTALL VALVE, TAP LIGHTLY TO CENTER IN THROTTLE BORE. TIGHTEN SCREWS SECURELY.

POWER ADJUSTING NEEDLE (14) - TURN NEEDLE IN LIGHTLY UNTIL SEATED. THEN BACK OUT 1 TURN.

IDLE ADJUSTING NEEDLE (13) - TURN NEEDLE IN LIGHTLY UNTIL SEATED. THEN BACK OUT 1 1/2 TURNS.

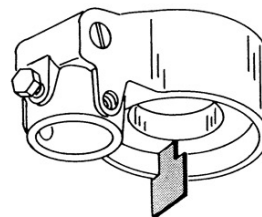

CAUTION: DO NOT EXERT PRESSURE ON RESILIENT NEEDLE VALVE.

TO ADJUST, BEND FLOAT LEVER.

FLOAT LEVEL ADJUSTMENT
HOLDING FLOAT BOWL UPSIDE DOWN, MEASURE FROM GASKET SURFACE OF BOWL.

DLTX 67-71-72-73 - 3/8"
ALL OTHER SINGLE DLTX, CORK OR METAL FLOATS - 1/2"

FLOAT ACTION: BE SURE THERE IS NO STICKING BETWEEN FINGERS ON FLOAT LEVER AND HEAD OF NEEDLE VALVE.

IDLE ADJUSTMENT. ENGINE AT OPERATING TEMPERATURE, CHOKE VALVE COMPLETELY OPEN, ADVANCE SPEED CONTROL LEVER TO WIDE OPEN THROTTLE POSITION WHICH WILL BE FAST IDLE OR GOVERNOR CONTROLLED IDLE. ADJUST IDLE ADJUSTING NEEDLE (13) UNTIL ENGINE RUNS EVENLY.

POWER ADJUSTMENT. WITH TRACTOR PULLING LOAD, TURN THE POWER ADJUSTING NEEDLE (14) CLOCKWISE UNTIL THE POWER DROPS OFF. THEN TURN THE NEEDLE COUNTERCLOCKWISE UNTIL ENGINE PICKS-UP POWER AND RUNS SMOOTHLY. SLIGHTLY RICHER MIXTURE MAY BE NECESSARY TO IMPROVE ACCELERATION. IF, WHEN LOAD IS RELEASED, GOVERNOR CLOSING THROTTLE CLEAR SHUT CAUSING UNEVEN RUNNING OR "HUNTING" (GOVERNOR OPENING AND CLOSING), TURN THE THROTTLE STOP SCREW AGAINST THE THROTTLE LEVER STOP SPRING UNTIL THE "HUNTING" IS CORRECTED AND IDLING IS SATISFACTORY.