

INSTRUCTION SHEET

OFF VEHICLE CARBURETOR SERVICE

SOLEX CARBURETOR - MODELS 30PICT-2, -3, 34PICT-3, -4

08050-504-1

1968 TO 1974 TYPE 1, 1968 TO 1971 TYPE 2

GENERAL EXPLODED VIEW

THE GENERAL DESIGN AND PARTS SHOWN WILL VARY TO
INDIVIDUAL UNITS COVERED ON THIS INSTRUCTION SHEET.

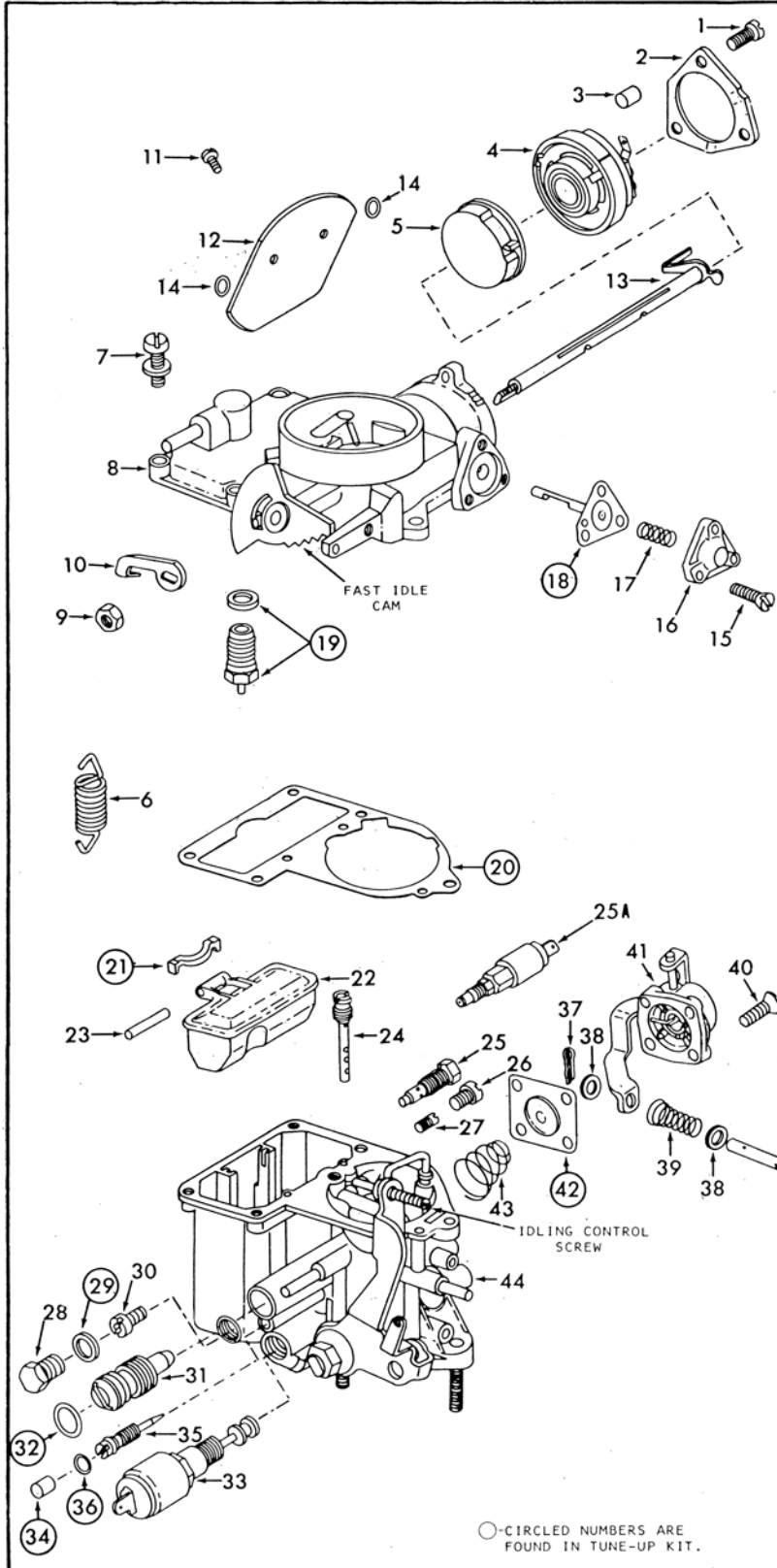

REMOVING

REMOVE OIL BATH AIR CLEANER. DETACH FUEL HOSE, VACUUM HOSE OF DASHPOT (WHERE APPLICABLE), AND VACUUM HOSE. DISCONNECT AUTOMATIC CHOKE CABLE, BYPASS AIR CUT-OFF VALVE CABLE (WHERE APPLICABLE), AND ELECTRO-MAGNETIC PILOT JET CABLE. DETACH ACCELERATOR CABLE AT THROTTLE VALVE LEVER. REMOVE TWO NUTS ON INTAKE MANIFOLD AND TAKE OFF CARBURETOR.

DISASSEMBLY

USE EXPLODED VIEW AS A GUIDE. THE NUMERICAL SEQUENCE MAY GENERALLY BE FOLLOWED TO DISASSEMBLE UNIT FAR ENOUGH TO PERMIT CLEANING AND INSPECTION. CAUTION: BRASS TUBE TYPE JETS ARE NOT REMOVABLE. BEFORE REMOVING CHOKE VALVE SCREWS (11) FILE OFF PEENED END FOR EASY REMOVAL. MARK LINKAGE RODS AND LEVERS SO THEY CAN BE RETURNED TO THE SAME POSITIONS.

NOMENCLATURE

REF. NO.	NOMENCLATURE	REF. NO.	NOMENCLATURE
1.	SCREW (3) - RETAINING RING	23.	PIN - FLOAT LEVER
2.	RETAINING RING - COVER	24.	JET - AIR CORRECTION
3.	SPACER BUSH - RETAINING RING	25.	JET - AUX IDLE SPEED FUEL
4.	COVER - WITH SPRING AND HEATER ELEMENT	25A.	VALVE - IDLE CUT OFF (30 PICT 2, 3)
5.	PLASTIC CAP	26.	PLUG - AUX FUEL JET
6.	SPRING - THROTTLE RETURN	27.	JET - AUXILIARY FUEL
7.	SCREW & LOCKWASHER (5) - UPPER BODY	28.	PLUG MAIN JET
8.	UPPER BODY ASSY	(29)	GASKET - PLUG
9.	NUT - CHOKE SHAFT	30.	JET - MAIN
10.	OPERATING LEVER - FAST IDLE CAM	31.	AIR SCREW - BYPASS
11.	SCREW (2) - CHOKE VALVE	(32)	O-RING - VOLUME CONTROL SCREW
12.	VALVE - CHOKE	33.	VALVE - BYPASS AIR CUT-OFF
13.	SHAFT - CHOKE	(34)	PLUG - VOLUME CONTROL SCREW
14.	SPACER WASHER (2) - CHOKE VALVE	35.	SCREW - VOLUME CONTROL
15.	SCREW (3) - COVER	(36)	O-RING - VOLUME CONTROL SCREW
16.	COVER - VACUUM DIAPHRAGM	37.	COTTER PIN
17.	SPRING - VACUUM DIAPHRAGM	38.	WASHER (2)
(18)	VACUUM DIAPHRAGM - CHOKE	39.	SPRING - CONNECTOR ROD
(19)	NEEDLE, SEAT & GASKET ASSY.	40.	SCREW (4) - COVER
(20)	GASKET - CARBURETOR BODY	41.	COVER - WITH LEVER & PIN
(21)	LUG - FLOAT PIN	(42)	DIAPHRAGM - PUMP
22.	FLOAT	43.	SPRING - DIAPHRAGM
		44.	CARBURETOR MAIN BODY ASSY

CLEANING

CLEANING MUST BE DONE WITH CARBURETOR DISASSEMBLED. SOAK PARTS LONG ENOUGH TO SOFTEN AND REMOVE ALL FOREIGN MATERIAL. USE A CARBURETOR CLEANING SOLVENT. MAKE CERTAIN THE THROTTLE BODY IS FREE OF ALL HARD CARBON DEPOSITS. WASH OFF IN SUITABLE SOLVENT. BLOW OUT ALL PASSAGES IN CASTINGS WITH COMPRESSED AIR AND CHECK CAREFULLY TO INSURE THOROUGH CLEANING OF OBSCURE AREAS. CAUTION: DO NOT SOAK SOLENOIDS, SWITCHES, FLOAT, OR RUBBER PARTS IN SOLVENTS.

REASSEMBLY

USING ESSENTIALLY THE REVERSE ORDER OF DISASSEMBLY GIVING SPECIAL ATTENTION TO THE FOLLOWING SPECIAL INSTRUCTIONS.

SPECIAL INSTRUCTIONS

MAKE SURE ALL JET ORIFICES ARE CLEAN AND OPEN. CLEAN WITH COMPRESSED AIR. DO NOT USE WIRES TO CHECK FOR CLOGGED ORIFICES. WHEN INSTALLING THE PUMP DIAPHRAGM AND SPRING (43) MAKE SURE THE LARGER END OF SPRING IS PROPERLY SEATED IN THE CARBURETOR BODY CAVITY. BE SURE TO INSTALL THE DIAPHRAGM (42) WITH PLUNGER TOWARD PUMP COVER (41).

CHECK FOR A WORN SPOT (DEPRESSION) ON THE FLOAT LEVER WHERE IT MAKES CONTACT WITH THE FUEL INLET NEEDLE VALVE. REPLACE FLOAT ASSEMBLY, IF NECESSARY. FLOAT ASSEMBLY MAY BE PURCHASED AT LOCAL VW DEALER. P/N 113-129-391 RECTANGULAR SHAPED FLOAT (22).

PROPER NEEDLE SEAT GASKET MUST BE USED FOR SPECIFIC CARBURETOR. USE THE FOLLOWING CHART TO DETERMINE THE CORRECT CARBURETOR MODEL

30 PICT-2	1.0 MM	.040"
30 PICT-3	1.5 MM	COMBINE 1.0 AND 0.5 MM GASKETS
34 PICT-3	0.5 MM	.020"

CHECK THE THERMOSTATIC SPRING IN HOUSING (ITEM #4) FOR DAMAGE. IF IT IS DISTORTED OR "KINKED", REPLACE THE ASSEMBLY. ALSO, MAKE SURE THE ELECTRICAL HEATING ELEMENT IS NOT BROKEN. THIS CAN BE CHECKED WITH AN OHMMETER OR CONNECTED TO A CORRECT VOLTAGE BATTERY FOR A FEW MINUTES TO SEE IF IT WARMS UP. (BE SURE TO GROUND THE INSIDE METAL PART OF THE HOUSING IN ORDER TO COMPLETE THE CIRCUIT.) WHEN INSTALLING THE ASSEMBLY WITH SPRING AND HEATER ELEMENT, CAREFULLY ROTATE ASSEMBLY COUNTERCLOCKWISE, BEING SURE THE HOOK ON COIL END ENGAGES WITH THE LEVER ON CHOKE SHAFT. CONTINUE ROTATING APPROXIMATELY 1/8-TURN MORE UNTIL INDEX MARKS ALIGN. THEN TIGHTEN SCREWS SECURELY.

INSTALLING

INSTALL IN REVERSE ORDER OF REMOVING.
TORQUE RETAINING NUTS TO 2.0 MKG. (14 FT LB.)

IDLING ADJUSTMENT

- A. CHECK IF THE AUTOMATIC CHOKE IS FULLY OPEN.
 - B. TURN IDLING CONTROL SCREW (SEE EXPLODED VIEW) OUT UNTIL THERE IS CLEARANCE BETWEEN SCREW AND FAST IDLE CAM.
 - C. THEN TURN IDLING CONTROL SCREW IN UNTIL IT JUST TOUCHES THE FAST IDLE CAM.
 - D. FROM THIRD POSITION, TURN SCREW IN FURTHER 1/4 OF A TURN.
 - E. TURN VOLUME CONTROL SCREW (ITEM #35) IN SLOWLY UNTIL IT COMES TO A STOP, AND THEN TURN IT BACK 2.5 TO 3 COMPLETE TURNS.
 - F. START ENGINE AND SET IDLE SPEED (900 RPM) BY TURNING THE BYPASS SCREW (ITEM #31).
 - G. BY TURNING VOLUME CONTROL SCREW (ITEM #35), ADJUST TO THE HIGHEST IDLE SPEED, THEN TURN IN UNTIL THE ENGINE SPEED DROPS BY 20-30 RPM.
 - H. RESET THE CORRECT IDLE SPEED BY TURNING THE BYPASS SCREW (ITEM #31).
- (NOTE 30 PICT-2 USE PROCEDURE ON PAGE 2.)

INSTRUCTION SHEET

SOLEX CARBURETOR — MODELS 28 PICT, -1, -2, 30 PICT - 1

1961 TO 1967 TYPE 1, 1961 TO 1967 TYPE 2

GENERAL EXPLODED VIEW

THE GENERAL DESIGN AND PARTS SHOWN WILL VARY TO INDIVIDUAL UNITS COVERED ON THIS INSTRUCTION SHEET.

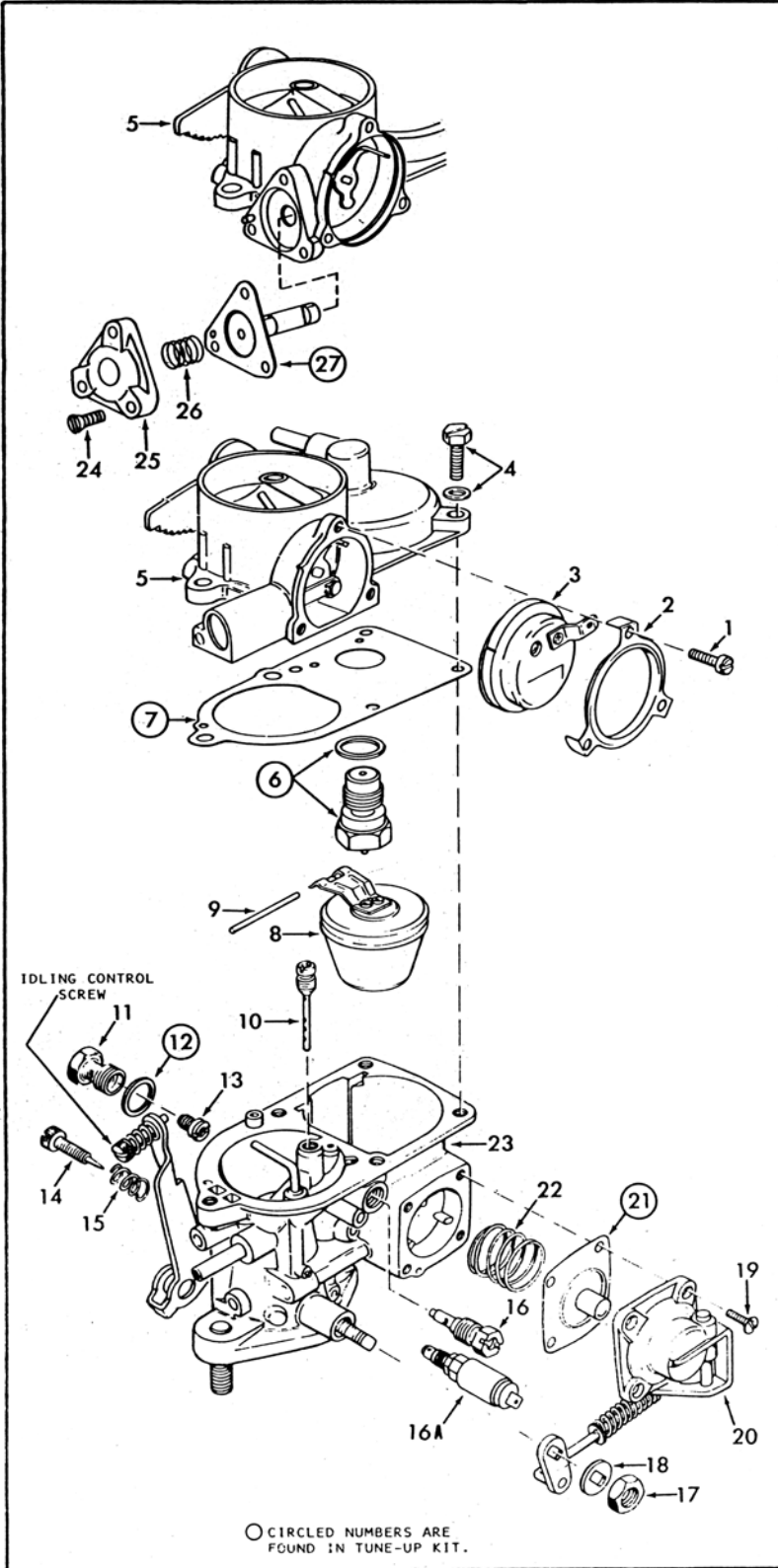

REMOVING

REMOVE OIL BATH AIR CLEANER. DETACH FUEL HOSE, VACUUM HOSE OF DASHPOT (WHERE APPLICABLE), AND VACUUM HOSE. DISCONNECT AUTOMATIC CHOKE CABLE, BYPASS AIR CUT-OFF VALVE CABLE (WHERE APPLICABLE), AND ELECTRO-MAGNETIC PILOT JET CABLE. DETACH ACCELERATOR CABLE AT THROTTLE VALVE LEVER. REMOVE TWO NUTS ON INTAKE MANIFOLD AND TAKE OFF CARBURETOR.

DISASSEMBLY

USE EXPLODED VIEW AS A GUIDE. THE NUMERICAL SEQUENCE MAY GENERALLY BE FOLLOWED TO DISASSEMBLE UNIT FAR ENOUGH TO PERMIT CLEANING AND INSPECTION. CAUTION: BRASS TUBE TYPE JETS ARE NOT REMOVABLE. WHEN NECESSARY TO REMOVE CHOKE SHAFT, BEFORE REMOVING VACUUM DIAPHRAGM (27) FILE OFF PEENED END OF CHOKE VALVE SCREWS FOR EASY REMOVAL. MARK LINKAGE RODS AND LEVERS SO THEY CAN BE RETURNED TO THE SAME POSITIONS.

NOMENCLATURE

REF. NO.	REF. NO.
1. SCREW (3) — RETAINING RING	15. SPRING — VOLUME CONTROL SCREW
2. RETAINING RING — COVER	16. JET — PILOT
3. COVER WITH SPRING AND HEATER ELEMENT	16A. VALVE — IDLING CUT — OFF
4. SCREW & LOCKWASHER (5) — UPPER BODY	17. NUT — THROTTLE SHAFT LEVER
5. UPPER BODY ASSY.	18. WASHER — THROTTLE SHAFT LEVER
6. NEEDLE, SEAT & GASKET ASSY.	19. SCREW (4) — COVER
7. GASKET — CARBURETOR BODY	20. COVER — WITH LEVER & LINKAGE
8. FLOAT	21. DIAPHRAGM — PUMP
9. PIN — FLOAT LEVER	22. SPRING — PUMP DIAPHRAGM
10. JET — AIR CORRECTION	23. CARBURETOR MAIN BODY ASSY.
11. CARRIER — MAIN JET	24. SCREW (3) — COVER
12. GASKET — CARRIER	25. COVER — VACUUM DIAPHRAGM
13. JET — MAIN	26. SPRING — VACUUM DIAPHRAGM
14. SCREW — VOLUME CONTROL	27. VACUUM DIAPHRAGM — CHOKE

CLEANING

CLEANING MUST BE DONE WITH CARBURETOR DISASSEMBLED. SOAK PARTS LONG ENOUGH TO SOFTEN AND REMOVE ALL FOREIGN MATERIAL. USE A CARBURETOR CLEANING SOLVENT. MAKE CERTAIN THE THROTTLE BODY IS FREE OF ALL HARD CARBON DEPOSITS. WASH OFF IN SUITABLE SOLVENT. BLOW OUT ALL PASSAGES IN CASTINGS WITH COMPRESSED AIR AND CHECK CAREFULLY TO INSURE THOROUGH CLEANING OF OBSCURE AREAS. CAUTION: DO NOT SOAK SOLENOIDS, SWITCHES, FLOAT, OR RUBBER PARTS IN SOLVENTS.

REASSEMBLY

USING ESSENTIALLY THE REVERSE ORDER OF DISASSEMBLY GIVING SPECIAL ATTENTION TO THE FOLLOWING SPECIAL INSTRUCTIONS.

SPECIAL INSTRUCTIONS

MAKE SURE ALL JET ORIFICES ARE CLEAN AND OPEN. CLEAN WITH COMPRESSED AIR. DO NOT USE WIRES TO CHECK FOR CLOGGED ORIFICES.

WHEN INSTALLING THE PUMP DIAPHRAGM AND SPRING (22) MAKE SURE THE LARGER END OF SPRING IS PROPERLY SEATED IN THE CARBURETOR BODY CAVITY. BE SURE TO INSTALL THE DIAPHRAGM (21) WITH PLUNGER TOWARD PUMP COVER (20).

CHECK FOR A WORN SPOT (DEPRESSION) ON THE FLOAT LEVER WHERE IT MAKES CONTACT WITH THE FUEL INLET NEEDLE VALVE. REPLACE FLOAT ASSEMBLY, IF NECESSARY. FLOAT ASSEMBLY MAY BE PURCHASED AT LOCAL VW DEALER, P/N 111-129-391A-ROUND SHAPED FLOAT (8).

PROPER NEEDLE SEAT GASKET MUST BE USED FOR SPECIFIC CARBURETOR. USE THE FOLLOWING CHART TO DETERMINE THE CORRECT GASKET.

CARBURETOR MODEL		
28 PICT-1,2	1.0 MM	.040"
30 PICT-1	1.0 MM	.040"

CHECK THE THERMOSTATIC SPRING IN HOUSING (ITEM #3) FOR DAMAGE. IF IT IS DISTORTED OR "KINKED", REPLACE THE ASSEMBLY.

ALSO, MAKE SURE THE ELECTRICAL HEATING ELEMENT IS NOT BROKEN. THIS CAN BE CHECKED WITH AN OHMMETER OR CONNECTED TO A CORRECT VOLTAGE BATTERY FOR A FEW MINUTES TO SEE IF IT WARMS UP. (BE SURE TO GROUND THE INSIDE METAL PART OF THE HOUSING IN ORDER TO COMPLETE THE CIRCUIT.) WHEN INSTALLING ASSEMBLY WITH SPRING AND HEATER ELEMENT, CAREFULLY ROTATE ASSEMBLY COUNTERCLOCKWISE, BEING SURE THE HOOK ON COIL END ENGAGES WITH THE LEVER ON CHOKE SHAFT. CONTINUE ROTATING APPROXIMATELY 1/8-TURN MORE UNTIL INDEX MARKS ALIGN. THEN TIGHTEN SCREWS SECURELY.

INSTALLING

INSTALL IN REVERSE ORDER OF REMOVING.
TORQUE RETAINING NUTS TO 2.0 MKG. (14 FT LB.)

IDLING ADJUSTMENT

28 PICT, -1, -2. 30 PICT-1, -2.

- WARM UP ENGINE; CHECK IF THE AUTOMATIC CHOKE IS FULLY OPEN.
- SET IDLING SPEED TO 850 RPM WITH THE IDLING CONTROL SCREW. (SEE EXPLODED VIEW)
- TURN VOLUME CONTROL SCREW (ITEM #14) TO RIGHT UNTIL SPEED STARTS TO DROP.
- FROM THIS POSITION, TURN VOLUME CONTROL SCREW (ITEM #14) TO THE LEFT UNTIL ENGINE RUNS FASTEST.
- IF NECESSARY, REGULATE THE ENGINE SPEED (800-900 RPM) AGAIN, WITH THE IDLING CONTROL SCREW.



100% Recycled
50% Post-Consumer Fiber