

INSTRUCTION SHEET

HITACHI S. U. CARBURETOR — MODEL HMB 46W

(DUAL CARBURETOR)

GENERAL EXPLODED VIEW

THE GENERAL DESIGN AND PARTS SHOWN WILL VARY TO
INDIVIDUAL UNITS COVERED ON THIS INSTRUCTION SHEET.

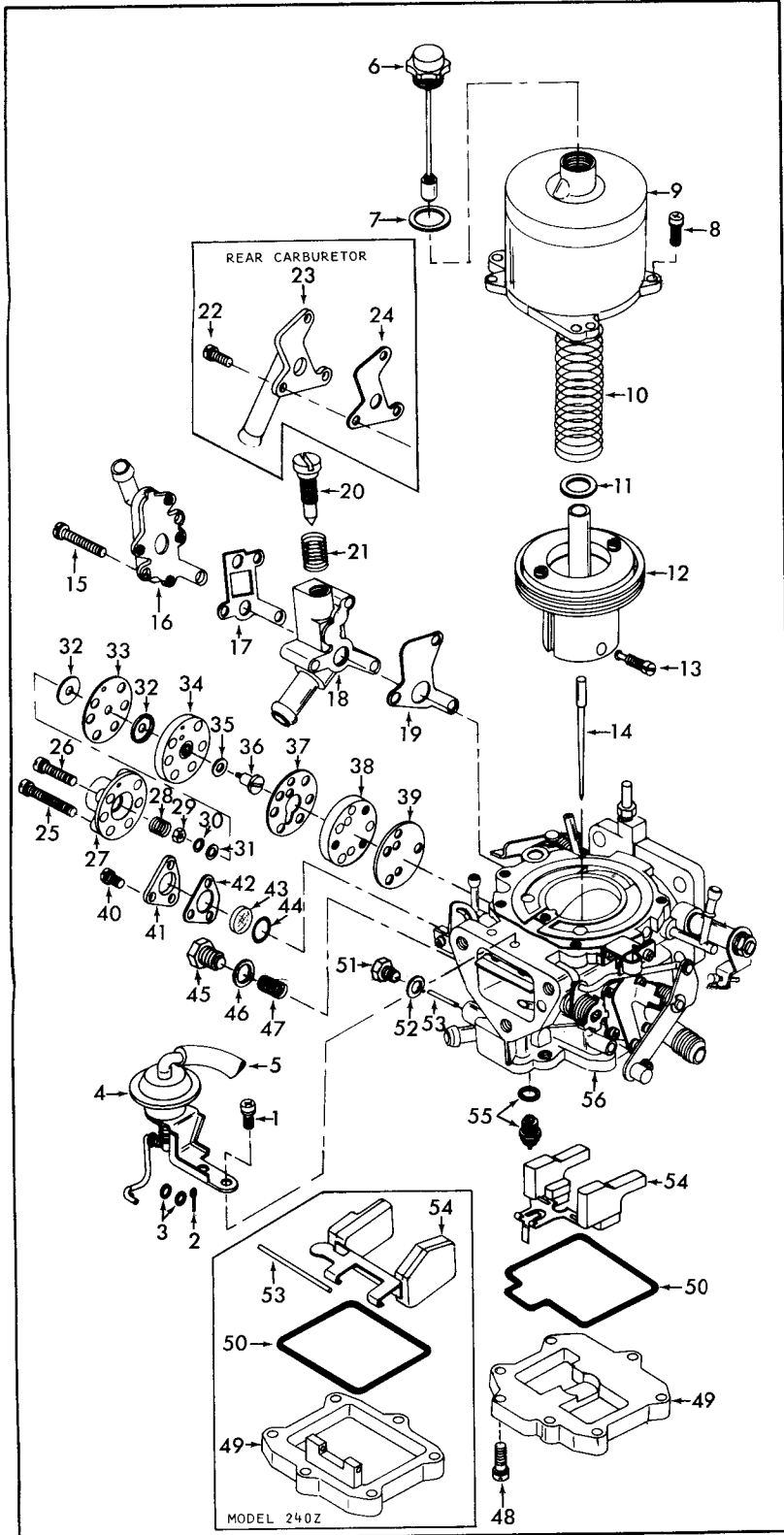

DISASSEMBLY

USE EXPLODED VIEW AS A GUIDE. ALWAYS DISASSEMBLE CARBURETORS INDIVIDUALLY AS PARTS SHOULD NOT BE INTERCHANGED. THE NUMERICAL SEQUENCE MAY GENERALLY BE FOLLOWED TO DISASSEMBLE UNIT FAR ENOUGH TO PERMIT CLEANING AND INSPECTION. CAUTION: SUCTION CHAMBER AND PISTON ASSY. ARE PRECISION MADE AND MUST NOT BE TREATED ROUGHLY. EXTREME CARE MUST BE TAKEN IN REMOVING FLOAT PIN ON LATE MODELS. TO REMOVE TAP HOUSING GENTLY JIGGLE FLOAT OR NUDGE FLOAT PIN WHERE IT CAN BE SEEN IN FLOAT CHAMBER. DO NOT REMOVE OR TAMPER WITH JET NEEDLE SETTING NUT.

NOMENCLATURE

REF. NO.	REF. NO.
1. SCREW & LOCKWASHER (2) - CHOKE PISTON ASSY.	27. COVER - DIAPHRAGM
2. COTTER PIN - PISTON LINK	28. SPRING - DIAPHRAGM
3. WASHER (2) - PISTON LINK	29. NUT - VALVE STEM
4. CHOKE PISTON ASSY.	30. LOCKWASHER - VALVE STEM
5. HOSE - CHOKE PISTON	31. FLAT WASHER - VALVE STEM
6. OIL CAP & DAMPER PISTON ASSY.	32. CUP WASHER (2) - DIAPHRAGM
7. GASKET - OIL CAP	33. DIAPHRAGM - POWER VALVE
8. SCREW & LOCKWASHER (3) - SUCTION CHAMBER	34. CENTER HOUSING - POWER VALVE
9. SUCTION CHAMBER	35. VALVE (RUBBER) - POWER STEM
10. SPRING - SUCTION PISTON	36. STEM - POWER VALVE
11. WASHER (PLASTIC) - SUCTION PISTON	37. GASKET - CIRCUIT PLATE
12. SUCTION PISTON ASSY.	38. CIRCUIT PLATE - POWER VALVE
13. SCREW - JET NEEDLE LOCK	39. GASKET - POWER VALVE MOUNTING
14. NEEDLE - JET	40. SCREW & LOCKWASHER (3) - WINDOW RETAINER
15. SCREW & LOCKWASHER (3) - IMS ASSY.	41. RETAINER - WINDOW
16. CONNECTOR PLATE ASSY. - AIR	42. GASKET - RETAINER
17. GASKET - AIR CONNECTOR	43. WINDOW - FUEL CHAMBER
18. BLOCK - IMS	44. O-RING - WINDOW SEAL
19. GASKET - IMS BLOCK	45. PLUG - FILTER SCREEN
20. SCREW - IMS ADJUSTING	46. GASKET - PLUG
21. SPRING - ADJUSTING SCREW	47. SCREEN - FILTER
22. SCREW & LOCKWASHER (3) - IMS CONNECTOR	48. SCREW & LOCKWASHER - COVER
23. CONNECTOR - IMS	49. COVER - FLOAT CHAMBER
24. GASKET - IMS CONNECTOR	50. GASKET - FLOAT CHAMBER COVER
25. SCREW & LOCKWASHER (3) LONG - POWER VALVE MOUNTING	51. PLUG - FLOAT PIN RETAINER (LATE MODEL)
26. SCREW & LOCKWASHER (3) SHORT - POWER VALVE ASSY.	52. GASKET - PLUG (LATE MODEL)
	53. PIN - FLOAT
	54. FLOAT & LEVER ASSY.
	55. NEEDLE, SEAT & GASKET ASSY.
	56. MAIN BODY ASSY.

CLEANING

CLEANING MUST BE DONE WITH CARBURETOR COMPLETELY DISASSEMBLED. USE A CARBURETOR CLEANING SOLVENT. SOAK PARTS LONG ENOUGH TO SOFTEN AND REMOVE ALL FOREIGN MATERIAL. DO NOT PROLONG SOAKING IN CARBURETOR CLEANER BECAUSE OF RUBBER SEALS THAT ARE NOT REMOVED. MAKE CERTAIN THE THROTTLE BORE IS FREE OF ALL CARBON AND VARNISH DEPOSITS. RINSE OFF IN SUITABLE SOLVENT. BLOW OUT ALL PASSAGES IN CASTINGS WITH COMPRESSED AIR AND CHECK CAREFULLY TO INSURE THOROUGH CLEANING OF OBSCURE AREAS. DO NOT SOAK PARTS CONTAINING DIAPHRAGMS, RUBBER OR PLASTIC MATERIAL SUCH AS (4)(5)(6)(16)(33)(35)(54).

REASSEMBLY

REASSEMBLE IN REVERSE ORDER OF DISASSEMBLY. NOTE SPECIAL INSTRUCTIONS AND ADJUSTMENTS.

SPECIAL INSTRUCTIONS

PISTON ASSY. (12) - LUBRICATE PISTON ROD LIGHTLY BEFORE INSTALLING (LUBRICATE NO OTHER PART OF PISTON.)

ADJUSTMENTS

